



# LT INDUCTION MOTORS



Making World Better

## VISION

Techno Industries Private Limited is committed to be a global leader by continuous innovation and producing quality Energy Efficient Products.



## MISSION

Our mission is to save power and be a part of building the Nation.



## VALUES

We are committed to be ethical, transparent to all our stake holders, making the World better to live for coming generations.



# CERTIFICATIONS

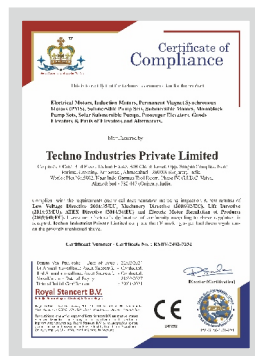

# ABOUT US

**TECHNO INDUSTRIES PRIVATE LIMITED** ( A Subsidiary of Lloyds Engineering Works limited). Established in 1984, is one of the leading Engineering Company in India. Our works and office are situated in Ahmedabad.

**TECHNO INDUSTRIES PRIVATE LIMITED** was awarded the prestigious National Award in recognition of outstanding Research & Development achievement by Government of India in 2008.

Our Core strength being & engineering, the company has been able to successfully establish Products to meet customer satisfaction across the globe in various segment, which includes, **MOTORS, PUMPS, ELEVATORS**

The Company's success is its 800+ hardworking employees guided by the dynamic management team with years of industrial experience and knowledge.

Its State-of-the-art manufacturing plant and fully equipped and modern testing facilities. The manufacturing range includes Electric Motors LT MOTORS 0.18 KW TO 1000 KW & HT MOTORS 200 KW TO 3500 KW. **TECHNO INDUSTRIES PRIVATE LIMITED** has been able to supply more than 20,00,000 Induction Motors for various applications and are operating satisfactorily in the field.

Our Motto is to provide well defined quality solutions with fast delivery and prompt pre & after sales service to our clients.

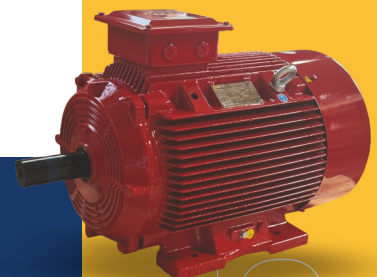

MOTORS



# OUR JOURNEY

01

Established **Techno Industries Pvt. Ltd.**  
In early 80s. It focused on manufacturing & Marketing pumps and motors.

1979  
1984

03

Received **R&D award**  
For high power testing facility  
And best entrepreneur award.

2008

05

Strategic entry of  
**LLOYDS ENGINEERING  
(LEWL)** to acquire  
majority stake in  
**TECHNO.**

2024

02

Expanded into the elevator and Escalator business. **35k elevators, 800k motors, 11.5 mn+ pumps** Delivered so far.

1994

2017

04

Recognized by Multiple Government Undertakings for Institutional Standards.

2025

06

**Plan to 5x broaden** its product Portfolio & strengthen its market Position, with the potential To expand into the b2c segment.



# INDEX

## PAGE NO.

<b>06</b>	SPECIFICATIONS
<b>06</b>	APPLICATIONS
<b>07</b>	FEATURES AND BENEFITS
<b>07</b>	BENEFITS OF ENERGY EFFICIENT MOTORS
<b>08</b>	STANDARDS FOR MOTORS
<b>09</b>	NOMINAL EFFICIENCY OF MOTORS & EFFICIENCY CLASS COMPARISON
<b>09</b>	EFFICIENCY CLASS COMPARISON
<b>10</b>	TOLERANCES
<b>11</b>	INSTALLATION CONDITIONS
<b>12</b>	NOISE LEVEL
<b>12</b>	VIBRATION LEVEL
<b>13</b>	DEGREE OF PROTECTION
<b>14</b>	MOUNTING ARRANGEMENTS
<b>15</b>	SPARE PARTS DESCRIPTION AND EXPLODED VIEW
<b>16</b>	INSULATION CLASS
<b>16</b>	MAJOR COMPONENTS
<b>17</b>	BEARING DETAILS & LUBRICATION
<b>17</b>	CABLE SIZE
<b>18</b>	3 PHASE INDUCTION MOTOR PERFORMANCE
<b>24</b>	MOTOR DIMENSIONAL DRAWING
<b>27</b>	CRAN & HOIST DUTY MOTORS ( TEFC)
<b>28</b>	PERMANENT MAGNET SYNCHRONOUS MOTORS (PMS MOTORS)
<b>29</b>	FIRE FIGHTING INDUCTION MOTOR
<b>30</b>	HT AC INDUCTION MOTORS
<b>31</b>	OUR CLIENTS

# SPECIFICATIONS

- Motor type : AC three-phase squirrel cage induction motor
- Enclosure : TEFC
- Frame : 63 to 400L
- Mounting : Foot, Flange and Face
- Rated power : 0.37 kW to 560 kW (0.5 to 750 HP)
- Voltage  $\pm$  variation : 415 V  $\pm$  10%
- Frequency  $\pm$  variation : 50 Hz  $\pm$  5%
- Combined variation : 10% (Absolute sum)
- Rated speed : 3000, 1500, 1000, 750 rpm (2 pole, 4 pole, 6 pole, 8 pole)
- Ambient temperature : +50°C
- Altitude : Should be lower than 1000 metres above sea level
- Relative humidity : Up to 100%
- Connection : Up to 2.2 kW-Star connection with 3 leads & above 2.2 kW-Delta connection with 6 leads
- Direction of rotation : Anticlockwise or clockwise as seen from the Driver end side
- Duty / Rating : S1 / Continuous
- Insulation class : Class 'F' and temperature rise limited to class 'B'
- Degree of protection : IP 55
- Cooling method : IC411 / Shaft mounted fan.

# APPLICATIONS



PUMPS



COMPRESSORS



FANS AND BLOWERS



FLOUR MILLS



PRINTING, PACKAGING AND  
WOOD WORKING MACHINERIES



TEXTILE AND  
PLASTIC MACHINERIES



MACHINE TOOLS



ROLLING MILLS, MIXERS



CRANES, HOISTS AND LIFTS



MATERIAL HANDLING  
EQUIPMENTS



AGRICULTURAL, FOOD  
PROCESSING MACHINERY



COOLING TOWERS

# FEATURES AND BENEFITS

- Motors are fitted with dynamically balanced aluminium die cast squirrel cage rotors.
- Motors are fitted with pre-lubricated antifriction ball bearings up to 132 frame.
- Motors are free from moisture and dust particles.
- Minimum electricity consumption because of special grade electrical steel used in an energy efficient optimized design.
- Balanced three-dimensional heat transfer principal due to special fins design of stator body.
- Minimum rotor losses due to use of electrolytic grade of aluminium.
- Minimum copper losses due to use of electrolytic grade of copper.
- Minimum friction losses.
- Low noise, smooth running motor.
- Reliable operation.
- Easy maintenance.
- Low payback period.

# BENEFITS OF ENERGY EFFICIENT MOTORS

- Short payback period / lower operating cost due to their higher efficiency.
- Motors have lower power dissipation due to their higher efficiency.
- Motors have a longer life span due to their relatively low temperature rise.
- Motors have higher thermal margins, which helps avoid unnecessary safety margins in the design process.
- Motors save energy and reduce CO2 emissions.

# FEATURES AND BENEFITS





# STANDARDS FOR MOTORS

All motors are complying with following Indian standards:

<b>IS:1231</b>	Dimensions of three phase foot mounted induction motors
<b>IS:1885</b>	Electro technical vocabulary : Part 35 Rotating machines
<b>IS:2223</b>	Dimensions of flange mounted ac induction machines
<b>IS:2254</b>	Dimensions of vertical shaft motors for pumps
<b>IS:3043</b>	Code of practice for earthing
<b>IS:6362</b>	Designation of methods of cooling of rotating electric machines
<b>IS:7816</b>	Guide for testing insulation resistance of rotating machines
<b>IS:12065</b>	Permissible noise levels for rotating electrical machines
<b>IS:12075</b>	Mechanical vibration of rotating electrical machines
<b>IS:13508</b>	Test procedure for measurement of loss tangent angle of coils and bars for machine winding-Guide
<b>IS:14222</b>	Impulse voltage withstand levels of rotating a.c. machines with form-wound stator coils
<b>IS:15999</b>	Rotating electrical machines: Part 2 Methods of tests, Section 1 Standard methods for determining losses and efficiency from tests(excluding machines for traction vehicles)
<b>IS:12615</b>	Energy efficient three phase squirrel cage induction motors

# NOMINAL EFFICIENCY OF MOTORS & EFFICIENCY CLASS COMPARISON

Nominal efficiency (%) limits for class **IE2 & IE3 50 Hz** according to the IS: 12615

P <sub>n</sub>		2-Pole Eff. (%)		4-Pole Eff. (%)		6-Pole Eff. (%)	
kW	HP	IE2	IE3	IE2	IE3	IE2	IE3
0.75	1	77.4	80.7	79.6	82.5	75.9	78.9
1.1	1.5	79.6	82.7	81.4	84.1	78.1	81.0
1.5	2	81.3	84.2	82.8	85.3	79.8	82.5
2.2	3	83.2	85.9	84.3	86.7	81.8	84.3
3.7	5	85.5	87.8	86.3	88.4	84.3	86.5
5.5	7.5	87.0	89.2	87.7	89.6	86.0	88.0
7.5	10	88.1	90.1	88.7	90.4	87.2	89.1
11	15	89.4	91.2	89.8	91.4	88.7	90.3
15	20	90.3	91.9	90.6	92.1	89.7	91.2
18.5	25	90.9	92.4	91.2	92.6	90.4	91.7
22	30	91.3	92.7	91.6	93.0	90.9	92.2
30	40	92.0	93.3	92.3	93.6	91.7	92.9
37	50	92.5	93.7	92.7	93.9	92.2	93.3
45	60	92.9	94.0	93.1	94.2	92.7	93.7
55	75	93.2	94.3	93.5	94.6	93.1	94.1
75	100	93.8	94.7	94.0	95.0	93.7	94.6
90	120	94.1	95.0	94.2	95.2	94.0	94.9
110	150	94.3	95.2	94.5	95.4	94.3	95.1
132	180	94.6	95.4	94.7	95.6	94.6	95.4
160	215	94.8	95.6	94.9	95.8	94.8	95.6
200 to 315	270 to 430	95.0	95.8	95.1	96.0	95.0	95.8

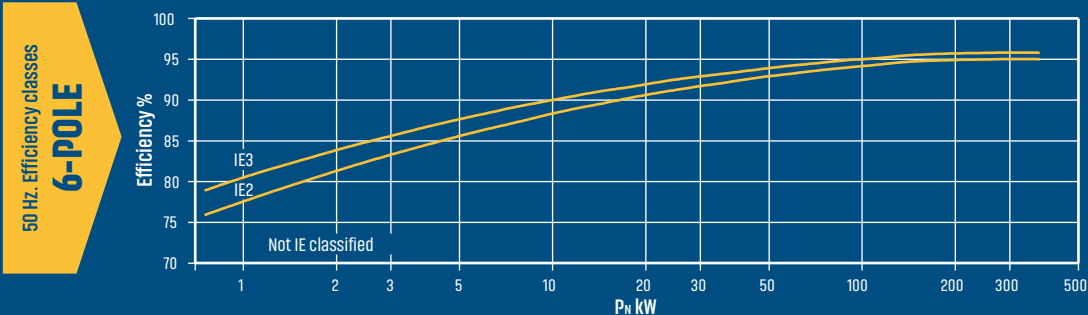
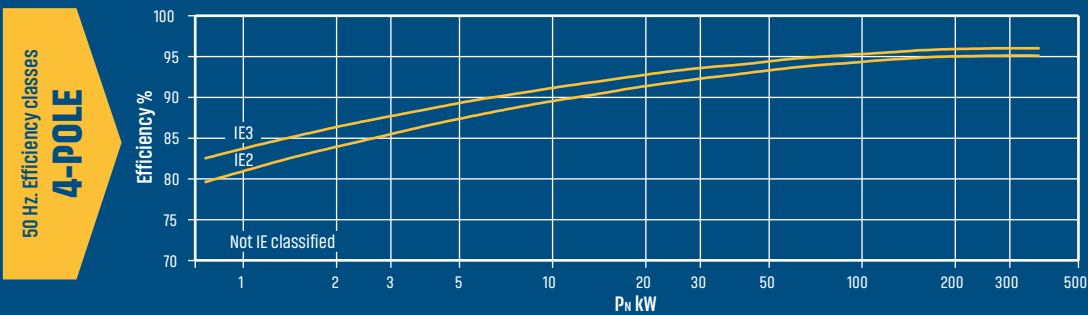
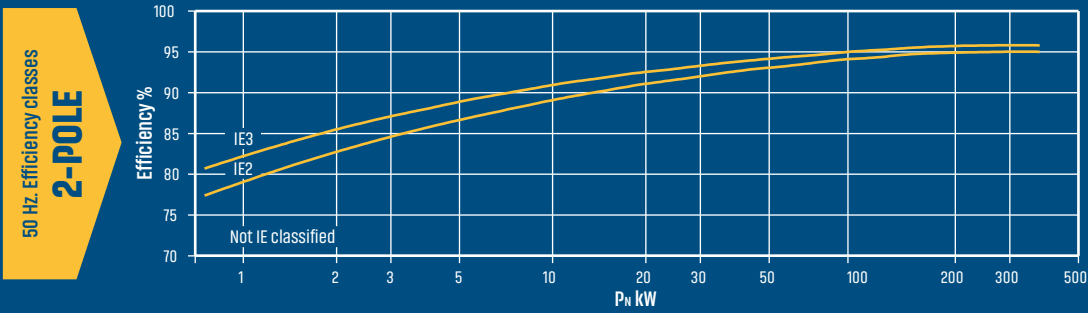

EFFICIENCY CLASS  
COMPARISON

# TOLERANCES

For industrial motors certain tolerances must be allowed on guaranteed values, taking into consideration the necessary tolerances for the manufacture of such motors and the materials used. The standard includes the following remarks:

- It is not intended that guarantees necessarily have to be given for all or any of the items involved. Quotations including guaranteed values subject to tolerances should say so, and the tolerances should be in accordance with the table.
- Attention is drawn to the different interpretation of the term guarantee. In some countries a distinction is made between guaranteed values and typical or declared values.
- Where a tolerance is stated in only one direction, the value is not limited in the other direction.

## Permissible deviation between real values & declared values

Power factor ( $\cos \varphi$ )	-1/6(1-cos $\varphi$ ) Minimum 0.02 and maximum 0.07
Efficiency ( $\eta$ )	-0.15(1- $\eta$ ) for $P_N \leq 150$ kW -0.1(1- $\eta$ ) for $P_N > 150$ kW Where $\eta$ is a decimal number
Slip (s)	$\pm 20\%$ of the slip for $P_N \leq 1$ kW $\pm 30\%$ of the slip for $P_N < 1$ kW
Locked rotor current ( $I_L/I_N$ )	+20% (No lower limit)
Locked rotor torque ( $T_L/T_N$ )	-15% and +25% (+25% may be exceeded by agreement)
Breakdown torque ( $T_B/T_N$ )	-10%
Moment of inertia (J) [ $\text{kgm}^2$ ]	$\pm 10\%$

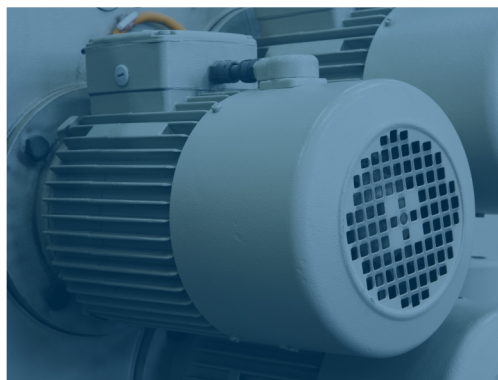

# INSTALLATION CONDITIONS

The standard design for horizontal mounting is suitable for indoor and protected outdoor installation (temperature of coolant -20°C to +40°C).

For unprotected outdoor installation or severe climatic conditions (moisture category wet, climate group WORLDWIDE, extremely dusty site conditions, aggressive industrial atmosphere, danger of storm rain and coastal climate, danger of attack by termites, etc.), as well as vertical mounting, special protective measures are recommended, such as:

- Protective cowl (for vertical shaft-down motors)
- For vertical shaft-up motors additional bearing seal and flange drainage
- Special paint finish
- Treatment of winding with protective moisture-proof varnish
- Anti-condensation heating (possibly winding heating)
- Condensation drain holes.

The special measures to be applied have to be agreed with the factory once the conditions of installation have been settled.

**The corresponding conditions of installation have to be clearly indicated in the order.**

## INSTALLATION AT ALTITUDES OF MORE THAN 1000 M ABOVE SEA LEVEL

CONDITIONS	ALTITUDE OF INSTALLATION		
	2000 m	3000 m	4000 m
At 40°C ambient temperature and thermal class 'B', Rated output reduce to approx	92%	84%	76%
At 40°C ambient temperature and thermal class 'F', Rated output reduce to approx	89%	79%	68%
Full nominal output to data tables with thermal class 'B' and ambient temperature of	32°C	24°C	16°C
Full nominal output to data tables with thermal class 'F' and ambient temperature of	30°C	19°C	9°C

The permissible nos. of starts per hour can be taken as given in the table below, provided the following conditions are met:  
Additional moment of inertia & moment of inertia of the rotor: load torque rising with the square of the speed up to nominal torque; starts at even intervals.

Frame size	2 Pole	4 Pole	6 & 8 Pole
63 - 71	100	250	350
80 - 100	60	140	160
112 - 132	30	60	80
160 - 180	15	30	50
200 - 225	8	15	30
250 - 355	4	8	12

# NOISE LEVEL

The permitted noise levels of electric machines are mention as per details below.

P <sub>N</sub>		IE2, IE3 NOISE LEVEL					
		2-Pole (3000 r/min)		4-Pole (1500 r/min)		6-Pole (1000 r/min)	
KW	HP	Measuring surface sound at 50 Hz Lpfa dB(A)	Sound pressure level at 50 Hz LWA dB(A)	Measuring surface sound at 50 Hz Lpfa dB(A)	Sound pressure level at 50 Hz LWA dB(A)	Measuring surface sound at 50 Hz Lpfa dB(A)	Sound pressure level at 50 Hz LWA dB(A)
0.75	1	56	67	46	57	45	57
1.1	1.5	57	68	48	60	45	57
1.5	2	61	73	48	60	49	61
2.2	3	61	73	52	64	53	65
3	4	63	75	52	64	53	65
3.7	5	65	75	53	65	55	67
5.5	7.5	68	80	59	71	55	67
7.5	10	68	80	59	71	57	69
11	15	72	84	62	72	57	69
15	20	73	86	62	73	58	70
18.5	25	73	86	64	76	58	70
22	30	74	87	64	76	61	73
30	40	77	91	64	76	62	74
37	50	77	91	64	76	62	74
45	60	77	91	65	78	63	75
55	75	80	94	66	79	64	76
75	100	80	94	69	82	68	80
90	120	80	94	69	82	68	80
110	150	81	95	77	90	73	83
132	180	81	95	77	90	73	83
160	215	85	99	82	95	78	90
200	270	85	99	82	95	78	90
250	340	88	102	84	97	78	90
315	430	88	102	84	97	-	-

# VIBRATION LEVEL

The amplitude of vibration in electric motors are governed by IS 12075, Mechanical vibration of rotating electrical machines with frame size 56 & large - methods of measurement and limits.

- Rotors are dynamically balanced with half key and the standard version meets the vibration levels of Grade A (without special vibration requirements) described in IS 12075. As an option, motors can be supplied in conformance with vibration of Grade B.
- The RMS speed and vibration levels in mm/s of Grade A and B are shown in below table.

Vibration	Assembly	Vibration speed RMS (mm/s)		
		Shaft height 63 ≤ H ≤ 132	Shaft height 132 < H ≤ 280	Shaft height H > 280
Grade A	Free suspension	1.6	2.2	2.8
Grade B	Free suspension	0.7	1.1	1.8











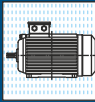
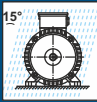
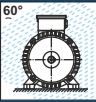

If the machine vibrates even after proper alignment on an amply size foundation, this could be cause by incorrect balanced pulley, coupling or similar, fitted to the shaft. Other causes could be weak foundation.

# DEGREE OF PROTECTION

## (INGRESS PROTECTION - IP)

The Degree of protection of a rotating electrical machine is designated with the letters IP (Ingress Protection) followed by two characteristic numbers, with the following manner:

- First characteristic numeral: Describes to protection against access to hazardous parts and ingress of solids & foreign bodies.
- Second characteristic numeral: Describes to protection against ingress of water.
- All our motors shown in this catalog are IP 55.

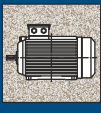
			Second numeral & description								
			0	1	2	3	4	5	6	7	8
First numeral & description			Not protected	Protection against vertically falling drops of water	Protection against direct spray of water up to 15° from vertical	Protection against direct spray of water up to 60° from vertical	Protection against water splashed from all directions	Protection against low pressure jet of water from any directions	Protection against strong jet of water from any directions	Protection against immersion between 0.15 & 1 m	Protection against long period of immersion under pressure
											
0	Not protected										
1	Protection against solid foreign bodies > 50 mm (e.g. Inadvertent contact with hand)										
2	Protection against solid foreign bodies > 12 mm (e.g. Inadvertent contact with the fingers)			IP 21	IP 22	IP 23					
3	Protection against solid foreign bodies > 2.5 mm (e.g. Inadvertent contact with wires and tools)										
4	Protection against solid foreign bodies > 1 mm (e.g. Inadvertent contact with wires, bands)						IP 44				
5	Protection against dust (no harmful deposits of dust)						IP 54	IP 55	IP 56		
6	Totally protected against deposition of dust										

# MOUNTING ARRANGEMENTS

Mounting arrangements for rotating electrical machines are designated. Our motors are available with the mounting arrangements as per details below, depending on design and frame size.

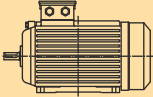
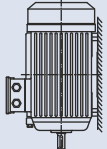
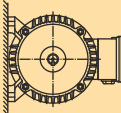
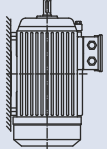
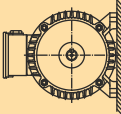
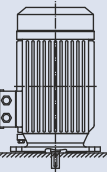
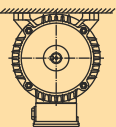
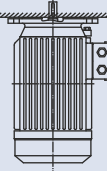
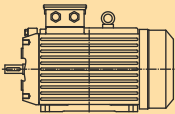
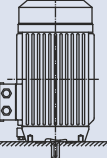
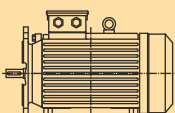
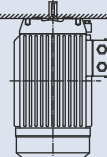
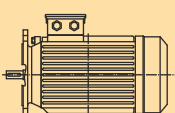
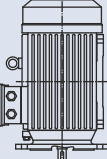
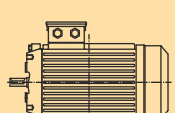
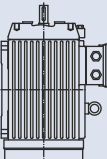
HORIZONTAL SHAFT MOUNTING					VERTICAL SHAFT MOUNTING				
Mounting arrangement	Code I	Code II	Frame size		Mounting arrangement	Code I	Code II	Frame size	
	IM B3	IM 1001	63 - 355			IM V5	IM 1011	63 - 160	
	IM B6	IM 1051	63 - 160			IM V6	IM 1031	63 - 160	
	IM B7	IM 1061	63 - 160			IM V1	IM 3011	63 - 355	
	IM B8	IM 1071	63 - 160			IM V3	IM 3031	63 - 160	
	IM B34	IM 2101	63 - 132			IM V18	IM 3611	63 - 132	
	IM B35	IM 2001	63 - 355			IM V19	IM 3631	63 - 132	
	IM B5	IM 3001	63 - 355			IM V15	IM 2011	63 - 160	
	IM B14	IM 3601	63 - 160			IM V37	IM 2131	63 - 132	

# SPARE PARTS DESCRIPTION AND EXPLODED VIEW

- |                       |                                 |                       |                    |
|-----------------------|---------------------------------|-----------------------|--------------------|
| 1 B5 flange           | 9 Hex bolt                      | 17 Gasket             | 25 Rear end shield |
| 2 B14 flange          | 10 Key                          | 18 Terminal plate     | 26 Grease nipple   |
| 3 Front end shield    | 11 Ball bearing (Drive end)     | 19 Terminal box base  | 27 V-seal          |
| 4 V-seal              | 12 Electric rotor               | 20 Gasket             | 28 Fan             |
| 5 Hex bolt            | 13 Ball bearing (Non-drive end) | 21 Screw              | 29 Fan cover       |
| 6 Spring washer       | 14 Stator stack                 | 22 Terminal box cover |                    |
| 7 Front bearing cover | 15 B3 stator frame              | 23 Lifting bolt       |                    |
| 8 Spring washer       | 16 B14 stator frame             | 24 Rear bearing cover |                    |

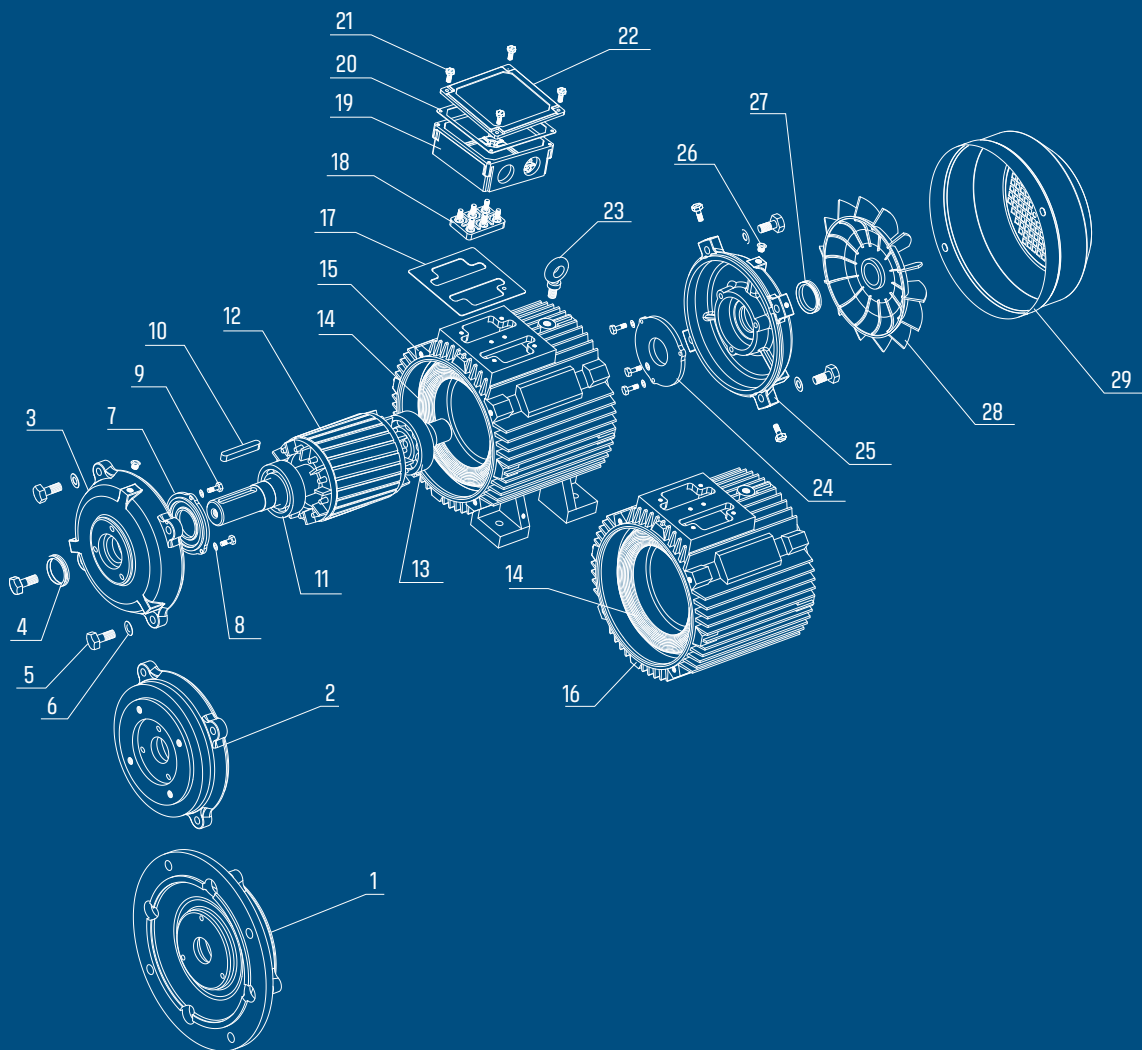

# INSULATION CLASS

Motors are manufactured with class 'F' insulation as a standard and temperature rise limited to class 'B'. This allows for about 25°C reserve thermal capacity in the motor. The reserve thermal capacity is what helps maintain the integrity of the insulation and lengthen motor life.

Temperature rise and maximum temperatures at the hottest points of the winding.

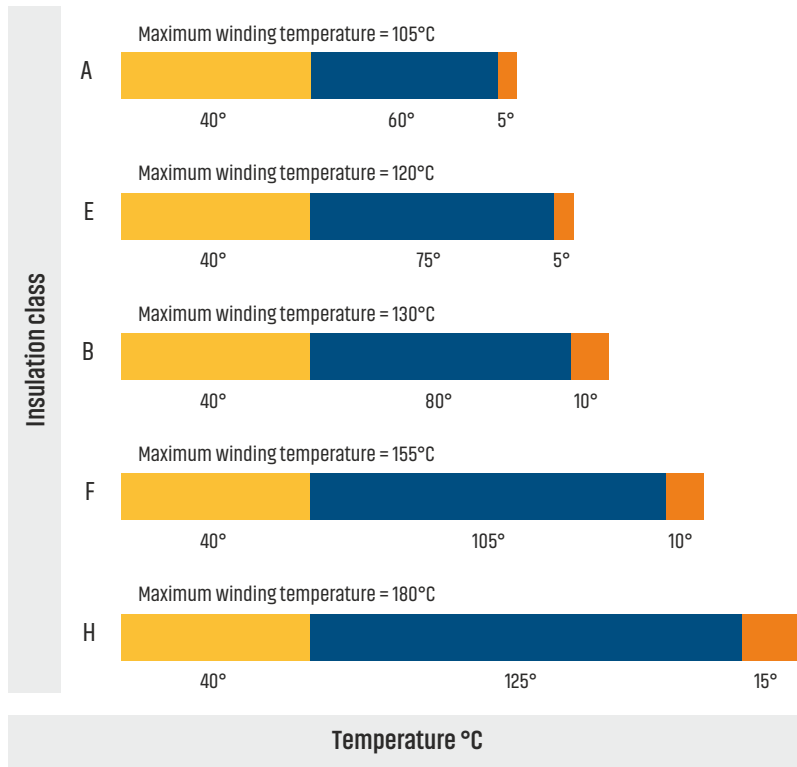

- Ambient temperature ●
- Maximum temperature rise ●
- Temperature margin ●

Ins. class	Maximum winding temperature
A	105°C
E	120°C
B	130°C
F	155°C
H	180°C

Insulation class 'F' in an electric motor means that at ambient temperature of 50°C, the temperature rise of the winding may be max. 95°C with the additional temperature margin of 10°C.

# MAJOR COMPONENTS

Sr. No.	Component	Material	Remarks
01	Housung	Cast Iron / Fabricated Steel	Optimally Sized Fins for Efficient Cooling
02	Stator	Insulated Silicon Steel (CRNGO), Super Enamel Copper Wire IS:4800 Part 5 Type 2 Advance NPN based Class 'F' insulation	Low Loss Consistency in Performance
03	Rotor	Aluminium Die Cast or Copper Strips in Insulated Silicon Steel (CRNGO)	Dynamically Balanced
04	Shaft	Carbon Steel 'EN 8'	Open Key Way
05	Endshield and Bearing Cover	Cast Iron	
06	Bearing & Lubrication	Ball / Roller Bearing and Lithium Complex based	Normal / C3 Clearance
07	Oil Seal	Synthetic Rubber	
08	Fan	Polypropylene / Aluminum Alloy	Bi-directional, Aerodynamically Designed
09	Fan Cover	Deep Drawn Steel	Lint Free Construction Available
10	Terminal Box	Aluminium / Cast Iron	IP:55 TOP / RHS / LHS Rotatable in the Steps of 90 Degree
11	Terminal Plate	Bakelite / Epoxy	Steel / Brass Stud 3/6 Terminals
12	Paint	Polyurethane	Protection Against Corrosion

# BEARING DETAILS & LUBRICATION

Frame size	Nos. of poles	Drive end bearing	Non-Drive end bearing	Regreasing interval [hours]	Regreasing Qty (gm.)
63	2	6201 ZZ-C3	6201 ZZ-C3	-	-
	4, 6, 8			-	-
71	2	6202 ZZ-C3	6202 ZZ-C3	-	-
	4, 6, 8			-	-
80	2	6204 ZZ-C3	6203 ZZ-C3	-	-
	4, 6, 8			-	-
90	2	6205 ZZ-C3	6204 ZZ-C3	-	-
	4, 6, 8			-	-
100	2	6206 ZZ-C3	6205 ZZ-C3	-	-
	4, 6, 8			-	-
112	2	6206 ZZ-C3	6205 ZZ-C3	-	-
	4, 6, 8			-	-
132	2	6308 ZZ-C3	6208 ZZ-C3	-	-
	4, 6, 8			-	-
160	2	6309 ZZ-C3	6209 ZZ-C3	-	-
	4, 6, 8			-	-
180	2	6310 ZZ-C3	6210 ZZ-C3	-	-
	4, 6, 8			-	-
200	2	6312 ZZ-C3	6212 / 6312 ZZ-C3	-	-
	4, 6, 8			-	-
225	2	6313 ZZ-C3	6213 / 6312 ZZ-C3	-	-
	4, 6, 8			-	-
250	2	6314 C3	6314 C3	3000	26
	4, 6, 8			7000	-
280	2	6314 C3	6314 C3	3000	26
	4, 6, 8	6318 C3	6318 C3	5000	40
315	2	6315 C3	6315 C3	2000	30
	4, 6, 8	6319 C3	6319 C3	4000	45
355	2	6318 C3	6318 C3	2000	40
	4, 6, 8	6322 C3	6319 C3	3000	45

NOTE: Grease make: UNIREX-N3 • Anti-friction bearing of Techno motors are designing for a bearing lifetime. • Lh10 > 40.00 hours ( Standard conditions )

## TERMINAL BOX

Terminal box is provided on top as a standard.

## CABLE SIZE

Frame size	Maximum cable size	Cable entry size
TM63	1X3CX4 mm <sup>2</sup>	M20 X 1.5 – 2 No.
TM71	1X3CX4 mm <sup>2</sup>	M20 X 1.5 – 2 No.
TM80	1X3CX4 mm <sup>2</sup>	M20 X 1.5 – 2 No.
TM90SL	1X3CX4 mm <sup>2</sup>	M20 X 1.5 – 2 No.
TM100L	2X3CX6 mm <sup>2</sup>	M20 X 1.5 – 2 Nos.
TM112M	2X3CX10 mm <sup>2</sup>	M25 X 1.5 – 2 Nos.
TM132SM	2X3CX10 mm <sup>2</sup>	M25 X 1.5 – 2 Nos.
TM160ML	2X3CX25 mm <sup>2</sup>	M25 X 1.5 – 2 Nos.
TM180ML	2X3CX50 mm <sup>2</sup>	M25 X 1.5 – 2 Nos.
TM200L	2X3CX70 mm <sup>2</sup>	M40 X 1.5 – 2 Nos.
TM225SM	2X3CX120 mm <sup>2</sup>	M50 X 1.5 – 2 Nos.
TM250SM	2X3CX120 mm <sup>2</sup>	M50 X 1.5 – 2 Nos.
TM280SM	2X3CX185 mm <sup>2</sup>	M50 X 1.5 – 2 Nos.
TM315SM	2X3CX185 mm <sup>2</sup>	M50 X 1.5 – 2 Nos.
TM315L	2X3CX240 mm <sup>2</sup>	M63 X 1.5 – 2 Nos.
TM355	2X3CX240 mm <sup>2</sup>	M63 X 1.5 – 2 Nos.

# 3 PHASE INDUCTION MOTOR PERFORMANCE

**EFFICIENCY CLASS : IE3**

**3000 RPM (2-POLE)**

Voltage  
**415/380 ±10%**

Duty  
**S1**

Synchronous Speed  
**3000 rpm**

Insulation Class  
**F**

Frequency  
**50 ± 5%**

Phase  
**3**

Rotor  
**Squirrel Cage**

Ambient Temp.  
**50° C**

Combined Variation  
**±10%**

Pole  
**2**

Efficiency Class  
**IE3**

Protection  
**IP55**

Rated		Frame Size	Rated Full Load Speed (RPM)	Full Load Current (Amp.)		Full Load Torque (kg.m)	Efficiency(%)			Power Factor			D.O.L. Starting		Pull Out torque (%FLT)	Rotor GD <sup>2</sup> (kgm <sup>2</sup> )
kW	HP			380V	415V		FL	3/4 FL	1/2 FL	FL	3/4 FL	1/2 FL	Starting Current (%FLC)	Starting Torque (%FLT)		
0.18	0.25	63	2850	0.51	0.47	0.62	65.90	65.90	63.00	0.80	0.76	0.68	600	180	225	0.0009
0.25	0.33	63	2850	0.67	0.61	0.85	69.70	69.70	67.00	0.82	0.78	0.70	600	200	275	0.0011
0.75	1	80	2830	1.63	1.49	0.26	80.7	80.7	78.5	0.88	0.80	0.70	600	250	300	0.0041
1.1	1.5	80	2840	2.38	2.18	0.38	82.7	82.7	81.0	0.86	0.80	0.72	650	250	300	0.0053
1.5	2	90S	2870	3.13	2.87	0.51	84.2	84.2	83.3	0.86	0.81	0.74	650	250	300	0.0067
2.2	3	90L	2875	4.53	4.15	0.75	85.9	85.9	85.5	0.86	0.83	0.75	700	275	300	0.0089
3	4	100L	2880	5.95	5.45	1.01	87.1	87.1	85.5	0.89	0.84	0.75	750	300	300	0.027
3.7	5	100L	2885	7.27	6.66	1.25	87.8	87.8	87.3	0.89	0.87	0.75	740	275	330	0.026
5.5	7.5	132S	2910	10.81	9.90	1.84	89.2	89.2	88.2	0.87	0.84	0.78	700	200	250	0.065
7.5	10	132S	2920	14.52	13.30	2.50	90.1	90.1	89.0	0.88	0.85	0.78	700	250	300	0.080
9.3	12.5	160M	2930	17.47	16.00	3.09	90.7	90.7	88.0	0.88	0.85	0.78	700	180	250	0.152
11	15	160M	2930	21.08	19.30	3.66	91.2	91.2	90.0	0.88	0.84	0.77	700	180	250	0.152
15	20	160M	2930	28.39	26.00	4.99	91.9	91.9	90.0	0.88	0.85	0.80	700	200	250	0.193
18.5	25	160L	2935	33.86	31.00	6.14	92.4	92.4	90.0	0.90	0.88	0.82	770	200	300	0.239
22	30	180M	2945	40.41	37.00	7.28	92.7	92.7	91.5	0.89	0.87	0.80	650	200	250	0.427
30	40	200L	2945	53.51	49.00	9.92	93.3	93.3	91.8	0.91	0.88	0.82	700	200	250	0.720
37	50	200L	2970	67.6	61.9	12.1	93.7	93.7	92.3	0.90	0.87	0.80	700	250	300	0.947
45	60	225M	2950	80.82	74.00	14.86	94.0	94.0	93.0	0.90	0.87	0.82	700	220	275	1.893
55	75	250M	2963	98.84	90.50	18.08	94.3	94.3	92.5	0.90	0.89	0.84	650	200	275	2.181
75	100	280S	2980	132	121	24.5	94.7	94.7	93.3	0.91	0.87	0.83	700	200	260	4.50
90	120	280M	2975	156.17	143.00	29.47	95.0	95.0	94.0	0.92	0.89	0.85	700	200	250	5.299
110	150	315S	2983	200	183	35.9	95.2	95.2	93.3	0.88	0.82	0.80	700	240	270	8.08
132	180	315M	2985	232	212	43.1	95.4	95.4	93.3	0.91	0.85	0.81	700	240	270	9.57
160	215	315L	2985	289	265	52.2	95.6	95.6	93.4	0.88	0.85	0.80	700	240	270	13.31
180	240	315L	2988	310.16	284.00	58.67	95.7	95.7	94.5	0.92	0.90	0.85	700	200	250	14.603
200	270	355L	2986	344	315	65.2	95.8	95.8	93.7	0.92	0.88	0.84	700	200	250	15.74
225	300	355L	2987	388	355	73.4	95.8	95.8	93.8	0.92	0.88	0.84	700	180	240	18.17
250	335	355L	2987	432	396	81.5	95.8	95.8	93.8	0.92	0.90	0.86	700	200	250	19.66
280	375	355L	2988	481	440	91.3	95.8	95.8	93.8	0.92	0.89	0.86	700	180	240	21.65

• Applicable standard for testing & efficiency determination: IS 15999

• All performance values are subject to tolerance as per IS/IEC 60034-1

# 3 PHASE INDUCTION MOTOR PERFORMANCE

**EFFICIENCY CLASS : IE2**

**3000 RPM (2-POLE)**

Voltage  
**415/380 ±10%**

Duty  
**S1**

Synchronous Speed  
**3000 rpm**

Insulation Class  
**F**

Frequency  
**50 ± 5%**

Phase  
**3**

Rotor  
**Squirrel Cage**

Ambient Temp.  
**50° C**

Combined Variation  
**±10%**

Pole  
**2**

Efficiency Class  
**IE2**

Protection  
**IP55**

Rated		Frame Size	Rated Full Load Speed (RPM)	Full Load Current (Amp.)		Full Load Torque (kg.m)	Efficiency(%)			Power Factor			D.O.L. Starting		Pull Out torque (%FLT)	Rotor GD <sup>2</sup> (kgm <sup>2</sup> )
kW	HP			380V	415V		FL	3/4 FL	1/2 FL	FL	3/4 FL	1/2 FL	Starting Current (%FLC)	Starting Torque (%FLT)		
0.18	0.25	63	2850	0.57	0.52	0.06	60.40	60.40	58.00	0.79	0.75	0.67	600	180	225	0.0008
0.25	0.33	63	2850	0.71	0.65	0.09	64.80	64.80	62.00	0.82	0.78	0.70	600	200	275	0.0009
0.37	0.5	71	2800	1.08	0.99	0.13	69.50	67.50	65.00	0.74	0.68	0.60	500	260	300	0.0013
0.55	0.75	71	2810	1.42	1.30	0.19	74.10	72.00	70.00	0.79	0.72	0.58	500	270	300	0.0018
0.75	1	80	2825	1.76	1.61	0.26	77.4	76.5	74.0	0.82	0.74	0.62	550	250	280	0.0034
1.1	1.5	80	2840	2.58	2.36	0.38	79.6	78.5	77.0	0.82	0.75	0.63	600	250	300	0.0044
1.5	2	90S	2800	3.22	2.95	0.52	81.3	81.3	79.0	0.87	0.84	0.76	650	200	275	0.006
2.2	3	90L	2810	4.59	4.20	0.76	83.2	83.2	81.0	0.88	0.84	0.80	700	225	275	0.008
3	4	100L	2850	6.28	5.75	1.03	84.6	84.0	82.5	0.86	0.80	0.72	700	250	300	0.011
3.7	5	100L	2864	7.48	6.85	1.26	85.5	85.5	84.0	0.88	0.85	0.78	700	200	250	0.023
5.5	7.5	132S	2900	10.92	10.00	1.85	87.0	87.0	84.0	0.88	0.84	0.80	600	200	250	0.058
7.5	10	132S	2900	14.74	13.50	2.52	88.1	88.1	85.0	0.88	0.84	0.80	600	200	250	0.071
9.3	12.5	160M	2930	18.24	16.70	3.09	88.9	88.9	87.9	0.89	0.87	0.81	600	175	250	0.140
11	15	160M	2925	20.86	19.10	3.66	89.4	89.4	88.2	0.90	0.88	0.85	600	175	250	0.140
15	20	160M	2925	28.39	26.00	4.99	90.3	90.3	88.5	0.90	0.88	0.85	650	200	250	0.181
18.5	25	160L	2935	33.86	31.00	6.14	90.9	90.9	88.5	0.90	0.88	0.85	650	200	250	0.222
22	30	180M	2935	43.03	39.40	7.30	91.3	91.3	90.5	0.89	0.87	0.83	650	200	250	0.383
30	40	200L	2950	54.61	50.00	9.91	92.0	92.0	90.5	0.90	0.87	0.82	700	200	275	0.659
37	50	200L	2955	66.62	61.00	12.20	92.5	92.5	91.0	0.91	0.88	0.84	700	225	275	0.885
45	60	225M	2965	83.55	76.50	14.78	92.9	92.9	91.0	0.91	0.88	0.84	700	200	275	0.988
55	75	250M	2965	99.38	91.00	18.07	93.2	93.2	91.5	0.91	0.88	0.80	700	200	250	2.017
75	100	280S	2975	138.70	127.00	24.55	93.8	93.8	92.0	0.88	0.86	0.82	700	200	275	4.175
90	120	280M	2970	163.82	150.00	29.52	94.1	94.1	93.0	0.89	0.87	0.82	700	200	250	4.657
110	150	315S	2980	194.39	178.00	35.95	94.3	94.3	92.5	0.91	0.89	0.85	700	200	300	7.953
132	180	315M	2982	233	213	43.11	94.6	93.3	91.3	0.89	0.85	0.80	700	200	250	9.57
160	215	315L	2985	284	260	52.21	94.8	94.8	94.0	0.92	0.90	0.86	700	200	275	11.84
180	240	315L	2980	313	287	58.83	94.9	94.9	94.0	0.92	0.90	0.86	700	200	275	12.82
200	270	355L	2985	352	322	65.26	95.0	94.1	92.2	0.90	0.82	0.82	700	175	225	14.28
225	300	355L	2980	395	362	73.54	95.0	95.0	93.0	0.91	0.89	0.85	700	160	275	18.17
250	335	355L	2985	446	408	81.57	95.0	94.2	92.8	0.90	0.87	0.84	700	160	225	20.16
315	425	355L	2985	561	514	102.78	95.0	94.1	93.0	0.90	0.88	0.84	700	150	220	25.39

• Applicable standard for testing & efficiency determination: IS 15999

• All performance values are subject to tolerance as per IS/IEC 60034-1

# 3 PHASE INDUCTION MOTOR PERFORMANCE

**EFFICIENCY CLASS : IE3**

**1500 RPM (4-POLE)**

Voltage  
**415/380 ±10%**

Duty  
**S1**

Synchronous Speed  
**1500 rpm**

Insulation Class  
**F**

Frequency  
**50 ± 5%**

Phase  
**3**

Rotor  
**Squirrel Cage**

Ambient Temp.  
**50° C**

Combined Variation  
**±10%**

Pole  
**4**

Efficiency Class  
**IE3**

Protection  
**IP55**

Rated		Frame Size	Rated Full Load Speed (RPM)	Full Load Current (Amp.)		Full Load Torque (kg.m)	Efficiency(%)			Power Factor			D.O.L. Starting		Pull Out torque (%FLT)	Rotor GD <sup>2</sup> (kgm <sup>2</sup> )
kW	HP			380V	415V		FL	3/4 FL	1/2 FL	FL	3/4 FL	1/2 FL	Starting Current (%FLC)	Starting Torque (%FLT)		
0.12	0.16	63	1390	0.46	0.42	0.08	64.8	64.8	62.0	0.62	0.58	0.50	500	225	275	0.013
0.18	0.25	63	1390	0.62	0.57	0.13	69.9	69.9	68.0	0.63	0.58	0.50	500	225	275	0.016
0.25	0.33	71	1400	0.83	0.76	0.50	73.5	73.5	71.0	0.62	0.58	0.50	500	225	275	0.003
0.37	0.5	71	1400	1.09	1.00	0.58	77.3	77.3	75.0	0.67	0.63	0.58	600	225	275	0.004
0.75	1	80	1425	1.94	1.78	0.51	82.5	82.5	80.0	0.73	0.70	0.56	650	200	250	0.013
1.1	1.5	90S	1425	2.51	2.30	0.75	84.1	84.0	82.4	0.78	0.71	0.68	600	280	330	0.017
1.5	2	90L	1435	3.60	3.30	1.02	85.3	85.3	85.0	0.82	0.78	0.68	600	280	330	0.020
2.2	3	100L	1445	5.00	4.53	1.48	86.7	86.7	85.8	0.78	0.74	0.60	600	250	300	0.033
3	4	100L	1455	7.22	6.61	2.01	87.7	87.5	85.0	0.72	0.64	0.54	700	250	300	0.039
3.7	5	112M	1445	7.86	7.20	2.49	88.4	88.4	86.0	0.81	0.75	0.65	650	225	275	0.060
5.5	7.5	132S	1450	11.47	10.50	3.69	89.6	89.6	88.0	0.82	0.79	0.74	600	200	250	0.150
7.5	10	132M	1455	15.29	14.00	5.02	90.4	90.4	89.5	0.83	0.79	0.68	600	250	300	0.190
9.3	12.5	160M	1465	18.57	17.00	6.18	91.0	91.0	88.5	0.85	0.80	0.76	600	200	250	0.330
11	15	160M	1465	21.84	20.00	7.31	91.4	91.4	90.4	0.85	0.80	0.76	600	180	225	0.360
15	20	160L	1460	28.94	26.50	10.01	92.1	92.1	90.0	0.85	0.80	0.70	700	200	250	0.440
18.5	25	180M	1472	33.86	31.00	12.24	92.6	92.6	91.2	0.90	0.88	0.83	600	200	250	0.820
22	30	180L	1472	40.41	37.00	14.56	93.0	93.0	91.5	0.89	0.88	0.82	600	225	275	0.990
30	40	200L	1470	57.88	53.00	19.88	93.6	93.6	92.6	0.84	0.81	0.75	600	200	275	1.890
37	50	225S	1480	69.89	64.00	24.35	93.9	93.9	92.5	0.85	0.82	0.74	650	225	275	2.070
45	60	225M	1480	86.28	79.00	29.61	94.2	94.2	93.0	0.84	0.81	0.73	650	225	300	2.360
55	75	250M	1485	103.75	95.00	36.07	94.6	94.6	93.5	0.85	0.81	0.79	650	225	275	4.010
75	100	280S	1485	137.60	126.00	49.19	95.0	95.0	94.0	0.88	0.86	0.79	700	225	280	6.260
90	120	280M	1485	167.64	153.50	59.03	95.2	95.2	94.0	0.86	0.82	0.74	700	225	280	7.130
110	150	315S	1488	202.04	185.00	72.00	95.4	95.4	94.4	0.87	0.85	0.79	700	225	275	13.260
132	180	315M	1488	244.08	223.50	86.40	95.6	95.6	94.6	0.86	0.83	0.75	700	225	275	15.110
160	215	315L	1488	290.50	266.00	104.73	95.8	95.8	94.5	0.88	0.84	0.77	700	200	250	26.560
180	240	315L	1488	323.81	296.50	117.82	95.9	95.9	94.5	0.88	0.85	0.81	700	200	250	28.030
200	270	315L	1488	356.02	326.00	130.91	96.0	96.0	95.0	0.89	0.87	0.81	700	200	250	29.510
250	335	355L	1490	453.22	415.00	163.42	96.0	96.0	95.0	0.87	0.85	0.79	700	225	275	41.490
315	422	355L	1492	454.31	416	205.64	96.0	96.0	94.8	0.87	0.83	0.72	700	180	240	46.62
355	475	355L	1492	573.35	525	231.75	96.0	96.0	94.8	0.87	0.83	0.72	700	180	240	50.04

• Applicable standard for testing & efficiency determination: IS 15999

• All performance values are subject to tolerance as per IS/IEC 60034-1

# 3 PHASE INDUCTION MOTOR PERFORMANCE

**EFFICIENCY CLASS : IE2**

**1500 RPM (4-POLE)**

Voltage  
**415/380 ±10%**

Duty  
**S1**

Synchronous Speed  
**1500 rpm**

Insulation Class  
**F**

Frequency  
**50 ± 5%**

Phase  
**3**

Rotor  
**Squirrel Cage**

Ambient Temp.  
**50° C**

Combined Variation  
**±10%**

Pole  
**4**

Efficiency Class  
**IE2**

Protection  
**IP55**

Rated		Frame Size	Rated Full Load Speed (RPM)	Full Load Current (Amp.)		Full Load Torque (kg.m)	Efficiency(%)			Power Factor			D.O.L. Starting		Pull Out torque (%FLT)	Rotor GD <sup>2</sup> (kgm <sup>2</sup> )
kW	HP			380V	415V		FL	3/4 FL	1/2 FL	FL	3/4 FL	1/2 FL	Starting Current (%FLC)	Starting Torque (%FLT)		
0.12	0.16	63	1390	0.49	0.45	0.08	59.1	59.1	57.0	0.63	0.58	0.50	500	225	275	0.0011
0.18	0.25	63	1390	0.69	0.63	0.13	64.7	64.7	63.0	0.61	0.58	0.49	500	225	275	0.0013
0.25	0.33	71	1400	0.90	0.82	0.50	68.5	68.5	65.0	0.62	0.58	0.50	500	225	275	0.0025
0.37	0.5	71	1380	1.12	1.03	0.26	70.1	70.1	65.2	0.71	0.62	0.60	450	225	250	0.003
0.55	0.75	80	1400	1.49	1.36	0.38	77.1	77.1	75.0	0.73	0.69	0.60	600	200	250	0.009
0.75	1	80	1410	1.97	1.80	0.52	79.6	79.6	77.0	0.73	0.70	0.62	650	200	250	0.010
1.1	1.5	90S	1415	2.63	2.41	0.76	81.4	81.4	78.0	0.78	0.74	0.68	650	200	250	0.014
1.5	2	90L	1415	3.49	3.20	1.03	82.8	82.8	80.0	0.80	0.76	0.71	650	200	250	0.017
2.2	3	100L	1430	5.13	4.70	1.50	84.3	84.3	82.0	0.78	0.75	0.70	650	200	250	0.031
3	4	100L	1432	7.43	6.80	2.04	85.5	85.0	82.0	0.72	0.63	0.50	600	225	275	0.036
3.7	5	112M	1450	8.35	7.65	2.49	86.3	86.3	83.5	0.78	0.74	0.66	650	200	250	0.057
5.5	7.5	132S	1445	11.36	10.40	3.71	87.7	87.7	85.0	0.84	0.78	0.68	650	200	250	0.140
7.5	10	132M	1450	15.18	13.90	5.04	88.7	88.7	85.0	0.85	0.81	0.74	600	200	250	0.175
9.3	12.5	160M	1465	18.89	17.30	6.18	89.3	89.3	88.3	0.84	0.82	0.75	600	200	250	0.307
11	15	160M	1460	22.93	21.00	7.34	89.8	89.8	88.0	0.82	0.78	0.70	600	200	275	0.296
15	20	160L	1450	29.49	27.00	10.08	90.6	90.6	89.5	0.85	0.81	0.75	600	200	275	0.394
18.5	25	180M	1470	36.04	33.00	12.26	91.2	91.2	90.0	0.85	0.82	0.78	600	200	275	0.720
22	30	180L	1470	42.59	39.00	14.58	91.6	91.6	90.0	0.85	0.82	0.78	600	200	250	0.823
30	40	200L	1470	58.97	54.00	19.88	92.3	92.3	91.0	0.84	0.80	0.72	600	200	275	1.605
37	50	225S	1475	73.17	67.00	24.43	92.7	92.7	91.5	0.83	0.79	0.71	700	225	275	2.058
45	60	225M	1475	90.64	83.00	29.72	93.1	93.1	92.0	0.81	0.77	0.70	700	225	275	2.387
55	75	250M	1480	107.03	98.00	36.20	93.5	93.5	92.0	0.84	0.80	0.74	700	200	275	2.508
75	100	280S	1482	139.79	128.00	49.29	94.0	94.0	93.0	0.87	0.84	0.78	700	200	280	6.264
90	120	280M	1482	164.91	151.00	59.15	94.2	94.2	93.0	0.88	0.84	0.78	700	225	280	6.900
110	150	315S	1482	200.95	184.00	72.29	94.5	94.5	93.0	0.88	0.85	0.80	700	200	275	11.791
132	180	315M	1485	243.54	223.00	86.58	94.7	94.7	93.5	0.87	0.84	0.60	700	200	275	13.265
160	215	315L	1487	293	268	105	94.9	94.6	93.1	0.88	0.84	0.77	700	220	250	15.1
180	240	315L	1488	327.63	300.00	117.82	95.0	95.0	94.5	0.88	0.86	0.80	700	200	275	26.559
200	270	315L	1488	366	335	131	95.1	94.8	93.3	0.87	0.86	0.78	700	225	275	28.0
250	335	355L	1490	454.31	416.00	163.42	95.1	95.1	94.0	0.88	0.84	0.76	700	200	275	40.010
315	422	355L	1488	573	525	206	95.1	94.8	93.5	0.88	0.86	0.78	700	220	250	45.1
355	475	355L	1488	643	589	232	95.1	94.9	93.5	0.88	0.86	0.78	700	220	250	48.6

• Applicable standard for testing & efficiency determination: IS 15999

• All performance values are subject to tolerance as per IS/IEC 60034-1

# 3 PHASE INDUCTION MOTOR PERFORMANCE

**EFFICIENCY CLASS : IE3**

**1000 RPM (6-POLE)**

Voltage  
**415/380 ±10%**

Duty  
**S1**

Synchronous Speed  
**1000 rpm**

Insulation Class  
**F**

Frequency  
**50 ± 5%**

Phase  
**3**

Rotor  
**Squirrel Cage**

Ambient Temp.  
**50° C**

Combined Variation  
**±10%**

Pole  
**6**

Efficiency Class  
**IE3**

Protection  
**IP55**

Rated		Frame Size	Rated Full Load Speed (RPM)	Full Load Current (Amp.)		Full Load Torque (kg.m)	Efficiency(%)			Power Factor			D.O.L. Starting		Pull Out torque (%FLT)	Rotor GD <sup>2</sup> (kgm <sup>2</sup> )
kW	HP			380V	415V		FL	3/4 FL	1/2 FL	FL	3/4 FL	1/2 FL	Starting Current (%FLC)	Starting Torque (%FLT)		
0.12	0.16	63	930	0.55	0.50	0.125	57.7	57.7	55.0	0.58	0.52	0.45	450	200	250	0.0031
0.18	0.25	71	940	0.78	0.71	0.186	63.9	63.9	61.0	0.55	0.51	0.42	450	200	250	0.0046
0.25	0.33	71	940	1.00	0.92	0.26	68.8	68.8	65.0	0.55	0.51	0.42	450	200	250	0.0059
0.75	1	90S	945	2.07	1.90	0.77	78.9	78.9	76.0	0.71	0.62	0.50	600	225	275	0.021
1.1	1.5	90L	945	3.06	2.80	1.13	81.0	81.0	79.0	0.69	0.65	0.55	600	225	275	0.028
1.5	2	100L	950	3.82	3.50	1.54	82.5	82.5	80.0	0.74	0.68	0.53	600	200	250	0.051
2.2	3	112M	960	5.46	5.00	2.23	84.3	84.3	82.5	0.73	0.70	0.54	600	200	250	0.080
3.7	5	132S	960	9.39	8.60	3.75	86.5	86.5	85.0	0.70	0.68	0.64	600	180	225	0.152
5.5	7.5	132M	960	13.65	12.50	5.58	88.0	88.0	86.0	0.71	0.68	0.60	600	200	250	0.210
7.5	10	160M	970	16.38	15.00	7.53	89.1	89.1	88.0	0.80	0.76	0.67	600	175	250	0.462
9.3	12.5	160L	975	19.66	18.00	9.29	89.8	89.8	88.0	0.81	0.77	0.67	600	175	250	0.574
11	15	160L	975	23.15	21.20	10.99	90.3	90.3	89.0	0.80	0.76	0.70	600	175	250	0.602
15	20	180L	977	29.60	27.10	14.95	91.2	91.2	90.0	0.85	0.82	0.75	600	225	270	1.19
18.5	25	200L	977	37.13	34.00	18.44	91.7	91.7	91.0	0.83	0.80	0.72	600	200	250	1.87
22	30	200L	980	43.90	40.20	21.87	92.2	92.2	91.0	0.83	0.80	0.72	600	210	260	2.11
30	40	225M	985	58.43	53.50	29.66	92.9	92.9	91.5	0.84	0.82	0.75	600	200	275	3.74
37	50	250M	982	67.7	62.0	36.7	93.3	93.3	92.8	0.89	0.86	0.79	650	250	300	5.18
45	60	280S	984	87.9	80.5	44.5	93.7	93.7	93.0	0.85	0.80	0.72	600	250	300	8.54
55	75	280M	984	104.3	95.5	54.4	94.1	94.1	93.2	0.87	0.84	0.78	600	180	250	9.82
75	100	315S	992	142.0	130.0	73.6	94.6	94.6	93.6	0.85	0.82	0.72	600	250	300	14.16
90	120	315M	992	168	154	88.4	94.9	94.9	938.0	0.85	0.82	0.72	600	250	300	15.93
110	150	315M	992	204	187	108.0	95.1	95.1	94.2	0.85	0.82	0.72	600	250	300	18.14
132	180	315L	992	251	230	129.6	95.4	95.4	94.4	0.84	0.80	0.72	600	200	280	26.01
160	215	315L	990	289.41	265.00	157.41	95.6	95.6	94.5	0.88	0.85	0.80	700	200	250	29.96
180	240	355L	990	348	319	177	95.7	95.7	94.0	0.82	0.78	0.66	600	200	250	32.93
200	270	355L	991	378	346	197	95.8	95.8	94.1	0.84	0.80	0.70	600	180	240	50.64
225	300	355L	992	401.89	368.00	220.92	95.8	95.8	94.5	0.89	0.84	0.75	700	225	275	54.11
250	335	355L	992	476.16	436.00	245.46	95.8	95.8	94.5	0.84	0.81	0.70	700	225	275	57.59

• Applicable standard for testing & efficiency determination: IS 15999

• All performance values are subject to tolerance as per IS/IEC 60034-1

# 3 PHASE INDUCTION MOTOR PERFORMANCE

**EFFICIENCY CLASS : IE2**

**1000 RPM (6-POLE)**

Voltage  
**415/380 ±10%**

Duty  
**S1**

Synchronous Speed  
**1000 rpm**

Insulation Class  
**F**

Frequency  
**50 ± 5%**

Phase  
**3**

Rotor  
**Squirrel Cage**

Ambient Temp.  
**50° C**

Combined Variation  
**±10%**

Pole  
**6**

Efficiency Class  
**IE2**

Protection  
**IP55**

Rated		Frame Size	Rated Full Load Speed (RPM)	Full Load Current (Amp.)		Full Load Torque (kg.m)	Efficiency(%)			Power Factor			D.O.L. Starting		Pull Out torque (%FLT)	Rotor GD <sup>2</sup> (kgm <sup>2</sup> )
kW	HP			380V	415V		FL	3/4 FL	1/2 FL	FL	3/4 FL	1/2 FL	Starting Current (%FLC)	Starting Torque (%FLT)		
0.12	0.16	63	930	0.58	0.53	0.13	50.6	50.6	48.0	0.62	0.58	0.50	450	200	250	0.0025
0.18	0.25	71	940	0.87	0.80	0.19	56.6	56.6	54.0	0.55	0.51	0.42	450	200	250	0.0034
0.25	0.33	71	940	1.12	1.03	0.26	61.6	61.6	60.0	0.55	0.51	0.42	450	200	250	0.0046
0.37	0.55	80	910	1.24	1.14	0.40	67.6	67.6	64.0	0.68	0.62	0.48	500	200	250	0.010
0.55	0.75	80	940	1.66	1.52	0.57	73.1	73.1	71.0	0.69	0.65	0.55	600	200	250	0.012
0.75	1	90S	945	2.14	1.96	0.77	75.9	75.9	72.0	0.70	0.66	0.58	600	225	275	0.018
1.1	1.5	90L	930	3.28	3.00	1.15	78.1	78.1	76.0	0.66	0.62	0.50	450	190	250	0.024
1.5	2	100L	935	4.39	4.02	1.56	79.8	79.6	75.0	0.68	0.60	0.52	475	200	250	0.047
2.2	3	112M	940	6.01	5.50	2.28	81.8	81.8	79.8	0.72	0.65	0.58	500	200	250	0.07
3.7	5	132S	955	9.28	8.50	3.77	84.3	84.3	82.0	0.72	0.68	0.60	600	175	225	0.140
5.5	7.5	132M	955	14.09	12.90	5.61	86.0	86.0	84.0	0.69	0.65	0.53	600	200	240	0.187
7.5	10	160M	960	17.47	16.00	7.61	87.2	87.2	85.0	0.75	0.71	0.62	600	200	250	0.420
9.3	12.5	160L	965	20.75	19.00	9.39	88.1	88.1	86.0	0.77	0.73	0.65	600	200	250	0.504
11	15	160L	965	25.12	23.00	11.10	88.7	88.7	85.0	0.76	0.72	0.64	600	200	250	0.574
15	20	180L	975	30.58	28.00	14.98	89.7	89.7	88.5	0.83	0.80	0.74	600	200	240	1.092
18.5	25	200L	975	38.77	35.50	18.48	90.4	90.4	89.0	0.80	0.77	0.70	600	200	250	1.570
22	30	200L	975	44.78	41.00	21.98	90.9	90.9	89.5	0.83	0.79	0.74	600	225	260	1.967
30	40	225M	980	61.16	56.00	29.82	91.7	91.7	90.5	0.82	0.78	0.70	600	225	275	2.606
37	50	250M	985	72.62	66.50	36.59	92.2	92.2	91.0	0.84	0.80	0.72	650	200	275	4.437
45	60	280S	985	85.18	78.00	44.50	92.7	92.7	91.0	0.87	0.83	0.73	700	225	280	8.254
55	75	280M	984	107.9	98.8	54.4	93.1	93.1	90.8	0.86	0.83	0.76	600	225	250	9.39
75	100	315S	988	145.2	133.0	73.9	93.7	93.7	91.8	0.84	0.82	0.75	600	225	250	12.5
90	120	315M	989	174	159	88.6	94.0	94.0	92.7	0.84	0.80	0.74	600	225	250	14.3
110	150	315M	989	210	192	108.3	94.3	94.3	93.3	0.84	0.81	0.74	600	225	250	16.5
132	180	315L	990	250	229	129.9	94.6	94.6	93.8	0.84	0.81	0.74	600	225	250	24.4
150	200	315L	990	294	269	148	94.7	94.3	92.8	0.82	0.79	0.70	600	225	250	26.7
160	215	315L	990	301.42	276.00	157.41	94.8	94.8	93.5	0.85	0.82	0.75	700	200	275	28.318
180	240	355L	990	330.91	303.00	177.09	94.9	94.9	93.5	0.87	0.84	0.75	700	200	275	32.928
200	270	355L	990	380	348	197	95.0	94.7	93.5	0.84	0.80	0.70	600	225	250	49.0
250	335	355L	990	475	435	246	95.0	94.7	93.4	0.84	0.80	0.70	600	225	250	55.9
315	425	355L	992	581.00	532.00	309.28	95.0	95.0	94.0	0.88	0.83	0.75	700	180	275	64.540

• Applicable standard for testing & efficiency determination: IS 15999

• All performance values are subject to tolerance as per IS/IEC 60034-1

# B3 MOTOR DIMENSIONAL DRAWING

DRAWING

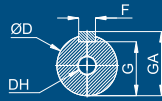
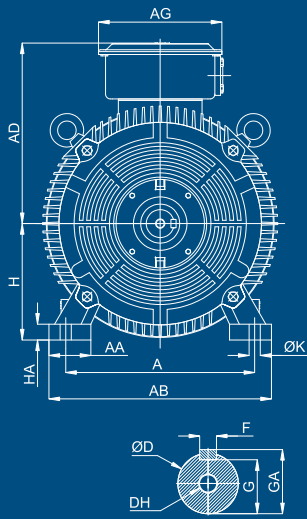

Section A-A

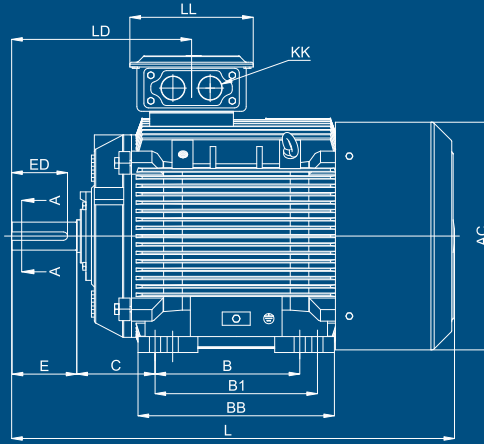

B3, 63 TO 250 FRAME

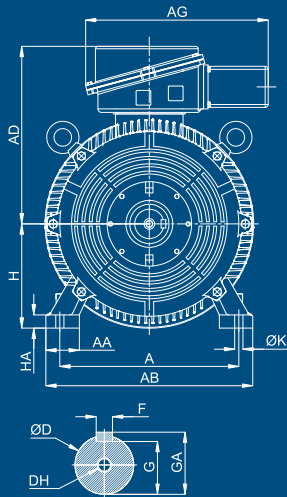

Section B-B

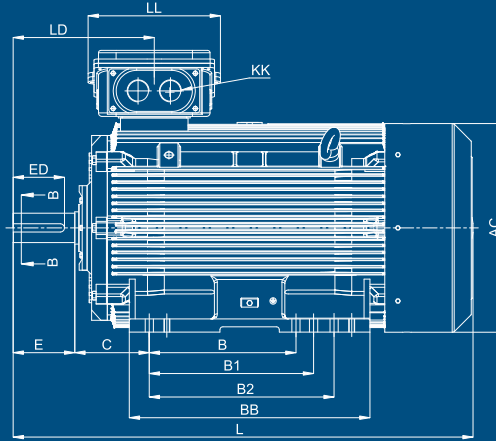

B3, 280 TO 355 FRAME

Frame	Pole	A	AA	AB	AC	AD	AG	B	B1	B2	BB	C	D	DH	E	ED	F	G	GA	H	HA	K	KK	L	LL	LD
63	2,4,6,8	100	24	122	119	111	85	80	-	-	102	40	11	M4	23	18.5	4	8.5	12.5	63	8	7	M16 X1.5	217	85	84
71	2,4,6,8	112	25	133	141	120	85	90	-	-	112	45	14	M5	30	25.5	5	11	16	71	8	7	M16 X1.5	246	85	92
80	2,4,6,8	125	32	150	159	141	99	100	-	-	128	50	19	M6	40	35.5	6	15.5	21.5	80	9	10	M20 X1.5	286	99	104
90SL	2,4,6,8	140	34	171	179	148	99	100	125	-	155	56	24	M8	50	45	8	20	27	90	10	10	M20 X1.5	339	99	120
100L	2,4,6,8	160	38	194	194	173	125	140	-	-	186	63	28	M10	60	55	8	24	31	100	12	12	Ø 21 X 2	401	125	149
112M	2,4,6,8	190	43	228	220	186	125	140	-	-	175	70	28	M10	60	50	8	24	31	112	14	12	Ø 21 X 2	408	125	152
132SM	2,4,6,8	216	50	253	260	208	125	140	178	-	215	89	38	M12	80	66	10	33	41	132	16	12	Ø 26 X 2	504	125	188
160ML	2,4,6,8	254	70	306	316	252	191	210	254	-	302	108	42	M16	110	87	12	37	45	160	22	15	Ø 26 X 2	662	191	257
180ML	2,4,6,8	279	70	340	352	272	191	241	279	-	321	121	48	M16	110	88	14	42.5	51.5	180	24	15	Ø 26 X 2	721	191	270
200ML	2,4,6,8	318	70	380	397	316	225	267	305	-	357	133	55	M20	110	89	16	49	59	200	26	19	Ø 42 X 2	769	225	290
225SM	2	356	80	435	447	359	265	286	311	-	370	149	55	M20	110	89	16	49	59	225	28	18.5	M50 X1.5	831	265	322
225SM	4,6,8	356	80	435	447	359	265	286	311	-	370	149	60	M20	140	120	18	53	64	225	28	18.5	M50 X1.5	861	265	352
250SM	2	406	90	478	489	388	265	311	349	-	422	168	60	M20	140	120	18	53	64	250	34	24	M50 X1.5	952	265	387
250SM	4,6,8	406	90	478	489	388	265	311	349	-	422	168	65	M20	140	120	18	58	69	250	34	24	M50 X1.5	952	265	387
280SM	2	457	102	535	528	446	482	368	419	-	492	190	65	M20	140	120	18	58	69	280	37	24	M50 X1.5	1082	314	387
280SM	4,6,8	457	102	535	528	446	482	368	419	-	492	190	75	M20	140	120	20	67.5	79.5	280	37	24	M50 X1.5	1082	314	387
315SM	2	508	105	594	590	487	482	406	457	-	535	216	65	M20	140	120	18	58	69	315	41	28	M50 X1.5	1175	314	407
315SM	4,6,8	508	105	594	590	487	482	406	457	-	535	216	80	M20	170	152	22	71	85	315	41	28	M50 X1.5	1205	314	437
315L	2	508	111	595	635	572	622	406	457	508	670	216	65	M20	140	120	18	58	69	315	42	28	M63 X1.5	1300	451	413
315L	4,6,8	508	111	595	635	572	622	406	457	508	670	216	80	M20	170	152	22	71	85	315	42	28	M63 X1.5	1330	451	443
355L	2	610	114	705	711	605	622	500	560	630	820	254	75	M20	170	151	20	67.5	79.5	355	45	28	M63 X1.5	1528	451	443
355L	4,6,8	610	114	705	711	605	622	500	560	630	820	254	100	M24	210	175	28	90	106	355	45	28	M63 X1.5	1568	451	481

# B5 MOTOR DIMENSIONAL DRAWING

DRAWING

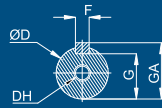
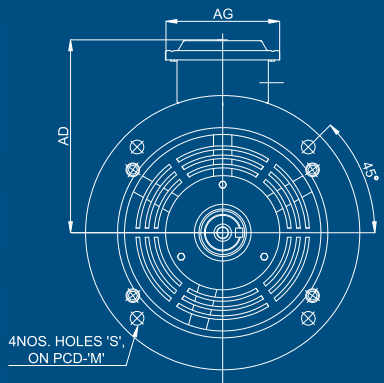

Section A-A

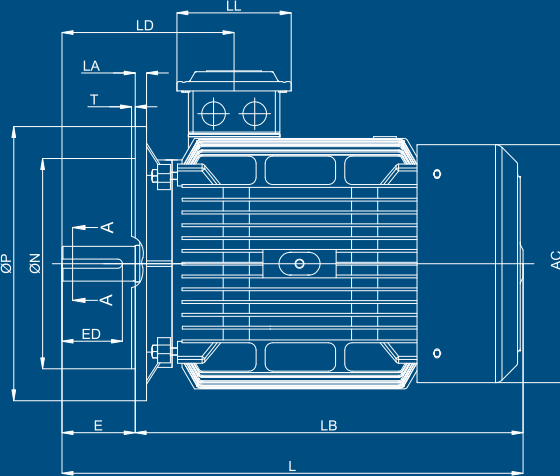

B5, 63 TO 200 FRAME

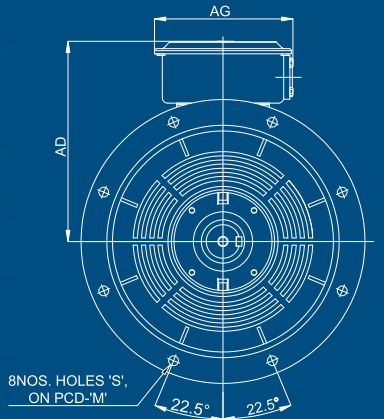

Section A-A

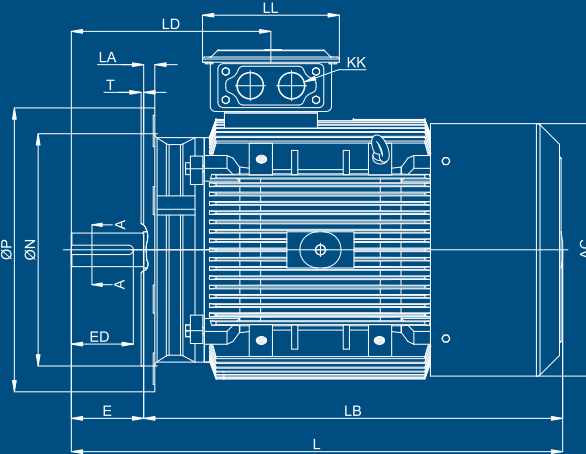

B5, 225 TO 355 FRAME

Frame	Pole	AC	AD	AG	D	DH	E	ED	F	G	GA	KK	L	LA	LB	M	N	P	S	T	LL	LD
63	2,4,6,8	119	111	85	11	M4	23	18.5	4	8.5	12.5	M16 X1.5	217	9.7	194	115	95	140	10	3	85	84
71	2,4,6,8	141	120	85	14	M5	30	25.5	5	11	16	M16 X1.5	246	9.7	216	130	110	160	10	3.5	85	92
80	2,4,6,8	159	141	99	19	M6	40	35.5	6	15.5	21.5	M20 X1.5	287	10.6	247	165	130	200	12	3.5	99	104
90L	2,4,6,8	179	148	99	24	M8	50	45	8	20	27	M20 X1.5	339	10.6	289	165	130	200	12	3.5	99	120
100L	2,4,6,8	194	173	125	28	M10	60	55	8	24	31	Ø 21 X 2	401	12	341	215	180	250	15	4	125	149
112M	2,4,6,8	220	186	125	28	M10	60	50	8	24	31	Ø 26 X 2	408	12	348	215	180	250	15	4	125	152
132SM	2,4,6,8	260	211	125	38	M12	80	66	10	33	41	Ø 26 X 2	504	12.5	424	265	230	300	15	4	125	188
160ML	2,4,6,8	316	252	191	42	M16	110	87	12	37	45	Ø 26 X 2	662	13	552	300	250	350	19	5	191	257
180L	2,4,6,8	352	272	191	48	M16	110	88	14	42.5	51.5	Ø 26 X 2	721	13	611	300	250	350	19	5	191	270
200ML	2,4,6,8	397	316	225	55	M20	110	89	16	49	59	Ø 42 X 2	769	18	659	350	300	400	19	5	225	290
225SM	2	447	359	265	60	M20	140	120	16	49	59	M50 X1.5	861	19	721	400	350	450	19	5	265	322
225SM	4,6,8	447	359	265	60	M20	140	120	18	53	64	M50 X1.5	861	19	721	400	350	450	19	5	265	352
250SM	2	489	388	265	60	M20	140	120	18	53	64	M50 X1.5	952	22	812	500	450	550	19	5	265	387
250SM	4,6,8	489	388	265	65	M20	140	120	18	58	69	M50 X1.5	952	22	812	500	450	550	19	5	265	387
280SM	2	528	446	482	65	M20	140	120	18	58	69	M50 X1.5	1082	18.6	942	500	450	550	19	5	314	387
280SM	4,6,8	528	446	482	75	M20	140	122	20	67.5	79.5	M50 X1.5	1082	18.6	942	500	450	550	19	5	314	387
315SM	2	590	487	482	65	M20	140	120	18	58	69	M50 X1.5	1205	28	1035	600	550	660	24	6	314	407
315SM	4,6,8	590	487	482	80	M20	170	152	22	71	85	M50 X1.5	1205	28	1035	600	550	660	24	6	314	437
315L	2	649	572	622	65	M20	140	120	18	58	69	M63 X1.5	1330	28	1160	600	550	660	24	6	451	413
315L	4,6,8	649	572	622	80	M20	170	152	22	71	85	M63 X1.5	1330	28	1160	600	550	660	24	6	451	443
355L	2	711	606	622	75	M20	170	151	20	67.5	79.5	M63 X1.5	1568	28	1358	740	680	800	24	6	451	443
355L	4,6,8	711	606	622	100	M24	210	175	28	90	106	M63 X1.5	1568	28	1358	740	680	800	24	6	451	481

# B14 MOTOR DIMENSIONAL DRAWING

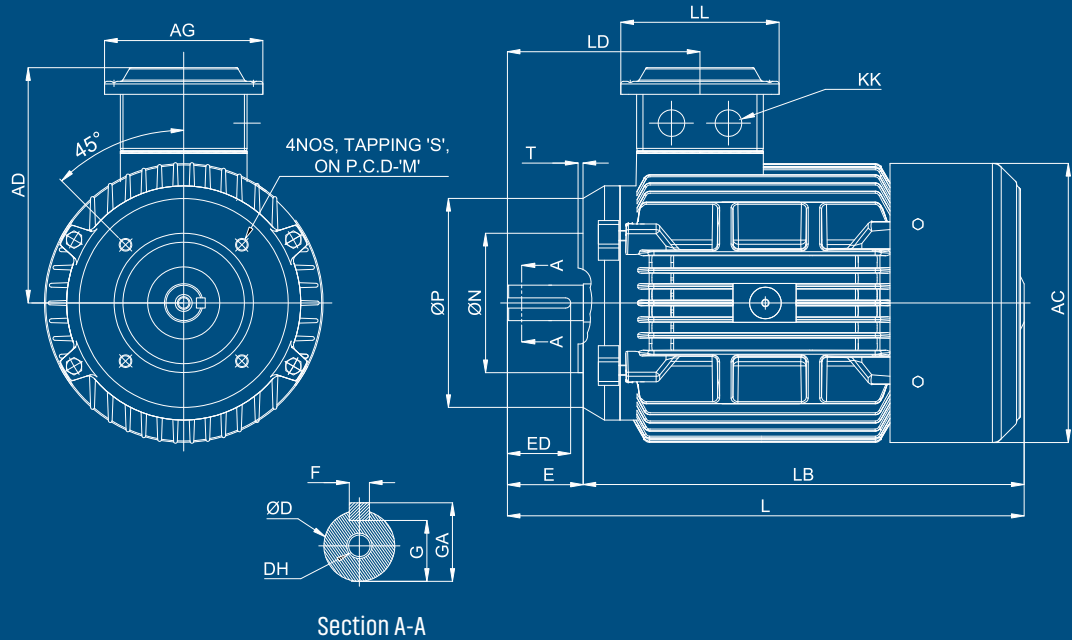

B14, 63 TO 112 FRAME

Frame	Pole	AC	AD	AG	D	DH	E	ED	F	G	GA	KK	L	LB	M	N	P	S	T	LL	LD
63	2,4,6,8	124	111	85	11	M4	23	18.5	4	8.5	12.5	M16X1.5	217	194	75	60	91	M5	2.5	85	84
71	2,4,6,8	147	120	85	14	M5	30	25.5	5	11	16	M16X1.5	246	216	85	70	105	M6	2.5	85	92
80	2,4,6,8	159	141	99	19	M6	40	35.5	6	15.5	21.5	M20X1.5	287	247	100	80	120	M6	3	99	104
90SL	2,4,6,8	179	148	99	24	M8	50	45	8	20	27	M20X1.5	339	289	115	95	140	M8	3	99	120
100L	2,4,6,8	194	173	125	28	M10	60	55	8	24	31	Ø 21 X 2	401	341	130	110	160	M10	3.5	125	149
112M	2,4,6,8	220	186	125	28	M10	60	50	8	24	31	Ø 26 X 2	408	348	130	110	165	M10	4	124	152

# CRAN & HOIST DUTY MOTORS ( TEFC )

**Range :** 0.18 Kw to 180 Kw

**Duty :** S4

**HP :** 0.25 HP to 250 HP

**Mountain :** B3 / IP 55

**RPM :** 1500 ( 4 Pole ) / 1000 ( 6 Pole )

**Start Per Hour :** 150 Starts / Stop Per Hour

**Insulation Class :** F class Insulation B class  
Temp. Rise & 40% CDF.

**Confirming to IS :** 12615:2018 ( IEC 60034 )



# PERMANENT MAGNET SYNCHRONOUS MOTORS (PMS MOTORS)

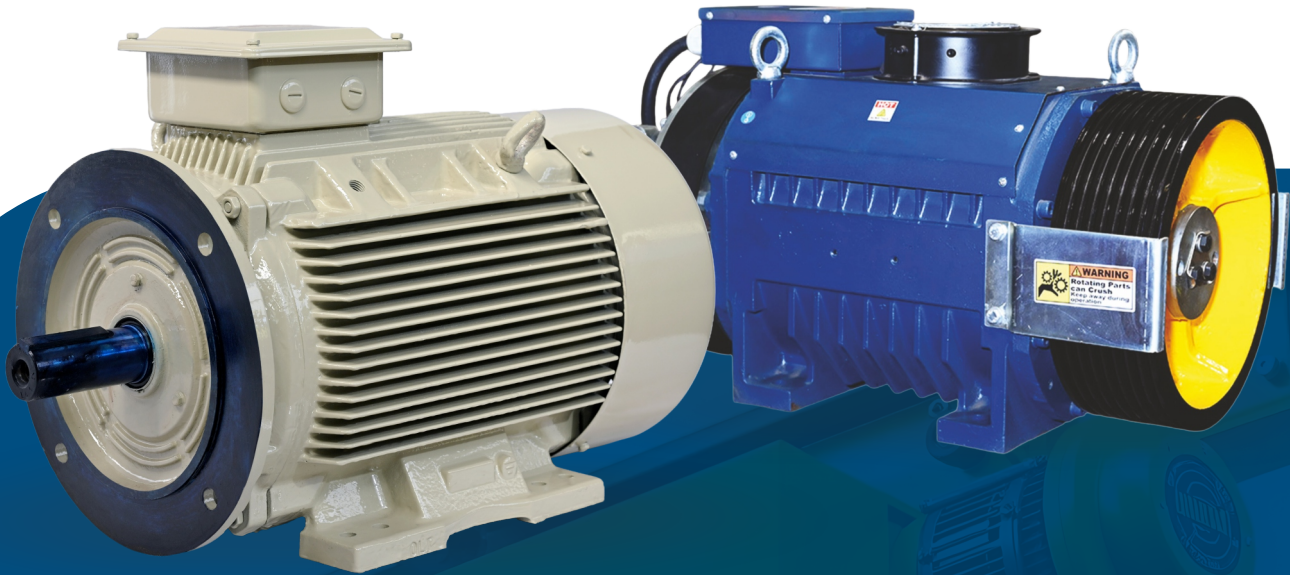

## RANGE:

**KW : 0.5 to 300**

**HP : 0.75 to 400**

**POLE : 2 to 66**

## Why PMS Motors?

### KEY ADVANTAGES

- High efficiency (Almost IE5 or above)
- High Power to weight ratio & Robustness
- Power Factor almost close to unity.
- Constant torque even at various RPMs (500/750/1500/3000 RPM)
- Compact design with high energy saving.

### MAJOR ADVANTAGES

- Maintenance Free
- Light in weight
- Easy to install
- Compact design with high energy saving
- Almost nil vibration
- Frequent start and stops will not have any impact on motor performance.
- Permanent Magnet Synchronous Motor has almost unique power factor.

# FIRE FIGHTING INDUCTION MOTOR



**KW : 3.7 KW TO 160 KW**

**HP : 5 HP TO 215 HP**

**RPM : 3000 ( 2 POLE )**

**Frame Size : 100M TO 280M**

**NOTE :**

- Standard Paint Shade: RAL3001 (Red)
- All frame size are available in Cast Iron body with Terminal Box on TOP as Standard.
- Terminal Box on LHS or RHS can be offered on Request.

# HT AC INDUCTION MOTORS

## RATINGS :

KW : 200 KW TO 3500 KW ( 3.3 KV, 6.6 KV & 11 KV

## NO OF POLE :

4 POLE, 6 POLE, 8 POLE, 10 POLE, 12 POLE

## CLASS OF INSULATION :

B Class, F Class, H Class.

## FREQUENCY :

50Hz / 60Hz

## FRAME SIZE :

280, 315,355,400,450,500,560 & 630

## COOLING METHOD :

IC411, IC416, IC611, IC616, 81W, 86W  
(Cooler, Fans, Heat Exchangers)

## MOTOR STANDARD :

NEMA MG-1 / IEEE 841 315,355,400,450,500,560 & 630

## STATOR SUPPLY WITH :

VPI Process

## MOUNTING :

B3, B5, D5, P5, C5.

## TYPE OF INCLOSURES :

- TOTALLY ENCLOSED FAN COOLED (TEFC)
- OPEN DRIP PROOF (ODP)
- TOTALLY ENCLOSED NON VENT (TENV)
- TOTALLY ENCLOSED AIR OVER (TEAO)



## APPLICATIONS :

- Cement and sugar Ind.
- Ports, Chemical, oil & Gas Ind.
- Food, Beverage and Pharmacy Ind.
- Mining & Metals
- Unit Handling
- Water & West water Ind.

## While placing order or inquiry, we need following Technical information :

- Application
- Ambient Temperature
- Mounting type
- Method of starting
- Input Supply Voltage and % Variance
- Required Frequency & Type of enclosures
- Protection Degree & Insulation class

# OUR CLIENTS



An ISO 9001/14001/45001/ CE CERTIFIED COMPANY

**TOLL FREE LINE 1800-102-5222**

Registered Office & Works  
**TECHNO INDUSTRIES PVT. LTD.**  
A Subsidiary of Lloyds Engineering Works Limited  
Plot No. 5002, Phase IV G.I.D.C, Vatva, Ahmedabad - 382 445 Gujarat - India

REGIONAL OFFICE : MUMBAI  
Unit No.39, 1st Floor, Madhu Estate, Lower Parel,  
Pandurang Budhkar Marg, Worli, Mumbai 400013.

**- BRANCHES -**

**SURAT**

204, Green Atria,  
B/H Green Elina,  
Opp. Snehsankur Wadi,  
Anand Mahal Road,  
Surat - 395009

**VADODARA**

116, Yash Complex,  
Gotri Road,  
Vadodara- 390021

**RAJKOT**

"Balaji Krupa" Shri Vridavan  
Co. OP. Housing Society,  
Street No.2, B/h Umiya Mobile,  
Panchayat Nagar Chowk,  
University Road, Rajkot

**DELHI**

Building No-21, Ground Floor,  
Shopping Complex,  
Nr. Milan Cinema Karampura,  
New Delhi-110015

**Nagpur**

C/O, Advo.A.S Pachpor,  
2nd Floor , House No - 161,  
NR. Nairsons Medical Service  
Ramnagar, Nagpur - 440033

**UDAIPUR**

33. Gayatri Nagar.  
Hiranmagri Sector-5. Udaipur  
(Meenakshi Hotel Street)



+91-079-2584 0266 | +91 79403 97257



sales@technoindustries.co.in



<http://www.technoindustries.co.in>



PROUDLY ENGINEERED & MANUFACTURED IN INDIA!

**Making World Better**

